

Operating manual

Gas pressure regulator RS350S PN10

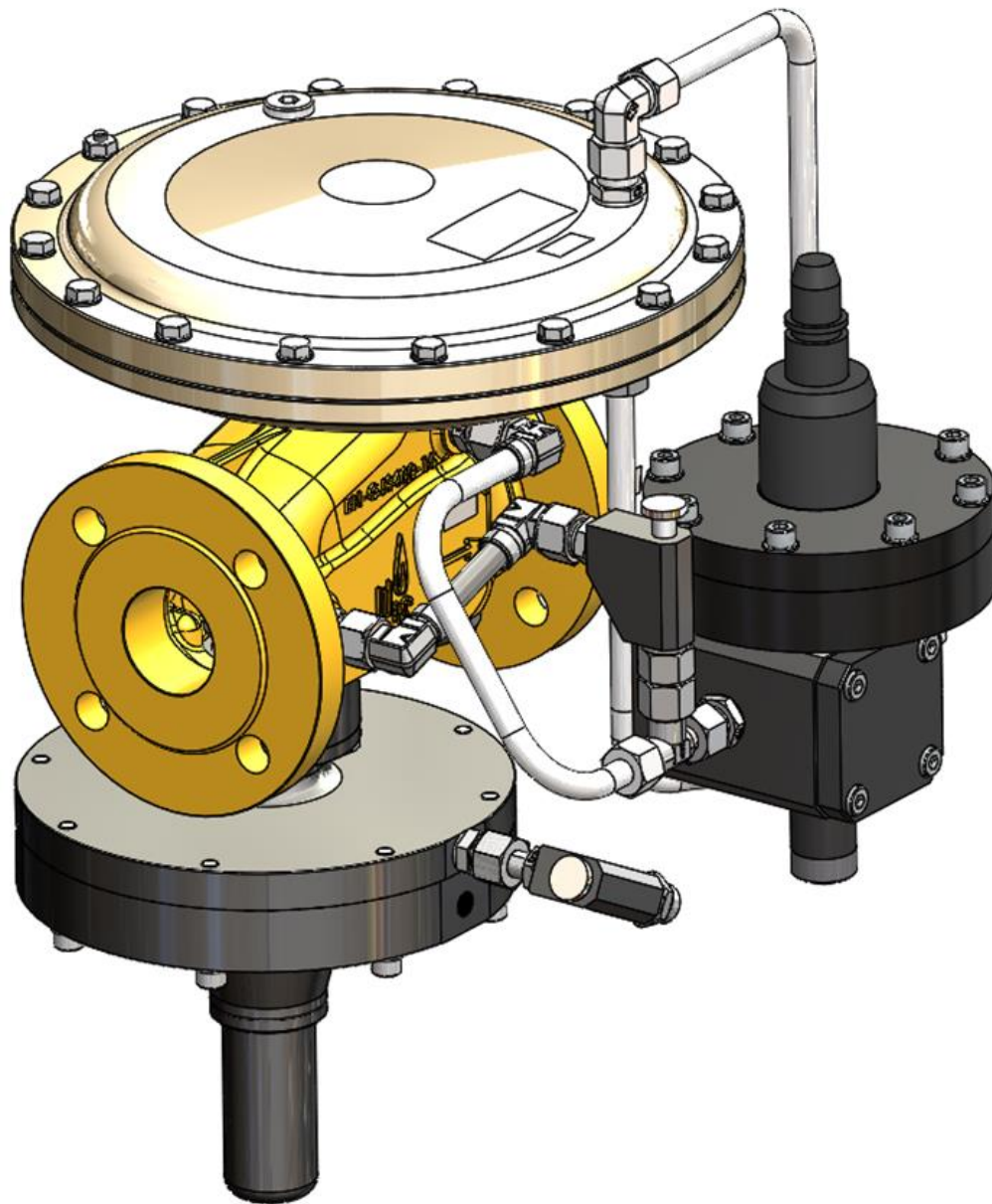

DN50

**Wigersma
& Sikkema**
Since 1921

Contents

Preface 2

1. Transport and storage 3

2. Installation instructions 3

3. Commissioning the gas pressure regulator 5

 3.1 Control points before commissioning 5

 3.2 Adjusting and operating the gas pressure regulator 6

 3.3 Method of commissioning 7

4. Adjusting the pilot 8

5. Verification of functioning 9

6. Decommissioning the gas pressure regulator 10

7. Maintenance 10

8. Control procedures 10

9. Regulator labels 11

10. Malfunction analysis 13

11. EU Declaration of Conformity 15

Preface

- This manual provides important information on the use of RS350S. Read this manual carefully.
- Various comments and warnings in this manual are marked with symbols. Read these carefully and, if necessary, take measures.

The symbols used have the following meanings:

| | |
|---|--|
|  REMARK | Suggestions and advice to make it easier to perform tasks. |
|---|--|

| | |
|---|--|
|  NOTE | A note alerts the user to possible problems. |
|---|--|

| | |
|--|---|
|  WARNING | If the operation is not performed correctly, a dangerous situation may arise or data or settings may be lost. |
|--|---|

The guarantee becomes invalid if the product described here is not handled properly, repaired or modified by unauthorized persons or if replacement parts are used which are not genuine parts from Wigersma & Sikkema B.V.

1. Transport and storage

To prevent damage to the gas pressure regulator during transport and storage, the following points must be observed carefully:



- The gas pressure regulator must be transported and stored in its original packaging.
- Transport and storage temperature -30 to + 60 °C.
- Impulse loads (shocks) must be avoided.
- The protective stickers and caps should only be removed during the installation of the regulator in the gas pressure regulator station to prevent dirt from getting into the gas pressure regulator.
- The gas pressure regulator must be hoisted at the lifting eyes. It is not permitted to lift the entire gas pressure regulation station by means of these lifting eyes.

2. Installation instructions

The gas pressure regulator is designed to be used in gas pressure regulating stations designed in accordance with NEN1059 : 2019. The gas pressure regulator is permanently corrosion treated and requires no further surface treatment. Any damage must be carefully repaired. Both the regulator and the pilot couplings are part of the design and must not be removed or exchanged.

Check that the gas pressure regulator has not been damaged during transport or storage and that it is suitable for the application. Pay particular attention to the medium, pressure and temperature range. Avoid excessive stress and/or impulse loads (e.g. impact from hammer) during installation. Installation is possible both horizontally and vertically. The regulator must be installed in such a way that the arrow on the body coincides with the direction of gas flow. After mounting the regulator in the station, the lifting eyes and underlying labels must be replaced by the washers and bolts supplied.

As standard, the pilot is mounted on the right-hand side of the regulator and can easily be moved to the left-hand side by relocating the original connections (cutting ring couplings) and pipes. If a different location is desired, the pilot can be mounted in any position, but as close to the regulator as possible. Please note that the original connections (cutting ring couplings) continue to be used due to restrictions. The maximum permissible length of the control line is 4 metres. If the pilot is relocated, it may be necessary to readjust the pilot.

The safety shut-off valve can be mounted in four positions on the controller body.

Air vents marked "P atmospheric breather" should always be horizontal or face downwards to prevent the ingress of dirt and moisture. The RS350S piping should be connected to a central pressure gauge as shown in Figure 1. The piping should be arranged so that any condensate **cannot** flow into the gas pressure regulator. Obstacles in the discharge pipework positioned near the controller can affect the controller's behaviour. See NEN1059 for measurement point regulations.

Indication of the connection points:

| <u>Pilot regulator</u> | <u>Function</u> | <u>Connection</u> |
|-------------------------|-------------------------------------|---|
| P atmospheric, breather | breather opening | N/A |
| Pu pilot regulator | inlet pressure | Pe pilot regulator on regulator housing |
| Pd sensing line | outlet pressure, sensing | header |
| Pd process line +Pup | return pressure regulator and drain | pilot regulator bottom side of membrane box and header |
| Pm | pilot pressure to regulator | top side of membrane box |

| <u>Safety shut-off valve</u> | <u>Function</u> | <u>Connection</u> |
|------------------------------|--------------------------|-------------------|
| P atmospheric, breather | breather opening | N/A |
| Pd sensing line | outlet pressure, sensing | header |

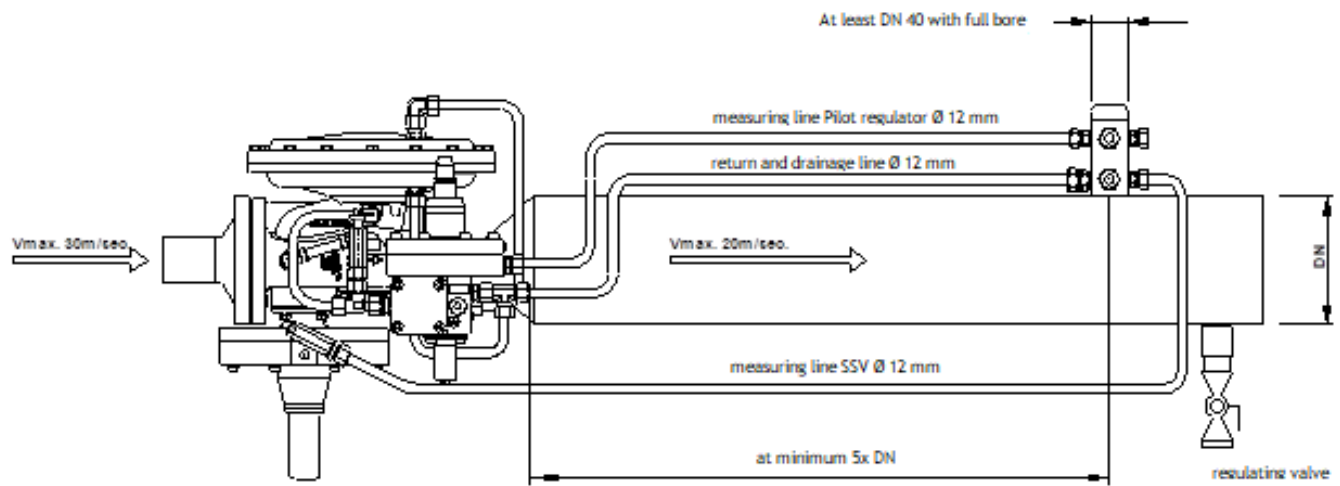

Figure 1

For outlet pressures below 50 mbar, the measuring line of the safety shut-off valve is equipped with a 3/2 valve N.O., so that the addressed safety shut-off valve can be pressurelessly restarted.

If the pressure regulating system is tested for strength with an integral regulator, the system must be closed at the inlet and outlet sides with plug-in flanges. The measuring and return pipes must also be removed (3x).

It is recommended to install a filter in accordance with NEN1059 in front of the regulator to protect the regulator from excessive contamination during operation.

3. Commissioning the gas pressure regulator



The next step releases gas.
Take measures to avoid dangerous situations.

3.1 Control points before commissioning

The gas pressure regulator may be put into service if the following conditions are met:

- Check that the set pressure value P_d corresponds to the design of the pressure regulating station.
See control report, which is supplied with the regulator.
- The exhaust side must be depressurized.
- The exhaust valve must be closed.



First apply pressure to the inlet section, then apply pressure to the outlet section.
This is to prevent warping of the diaphragm plate.

If the inlet pressure P_u is present (increase the pressure slowly), the pressure difference over the safety shut-off valve can be slowly released by actuating the pressure equalization valve on the body of the gas pressure regulator (see figure 2, item D).

During pressure equalization, P_d will rise to the set value. The safety shut-off valve can then be reset. The gas pressure regulator will deliver when the adjustment valve (see figure 1) is opened.

3.2 Adjusting and operating the gas pressure regulator

The schematic cross-sectional area of the gas pressure regulator (figure 2) indicates the positions of the controls by which the gas pressure regulator can be set or operated.

The gas pressure regulator is set at the factory as indicated on the inspection report and labels.

- A Adjusting the regulated outlet pressure P_d .
- B Adjusting the response pressure of the maximum pressure protection of the safety shut-off valve.
- C Spring response pressure of the minimum pressure protection of the safety shut-off valve (if present).
- D Pushbutton for actuating pressure equalization valve over safety shut-off valve.
- E Shaft safety shut-off valve for resetting the safety shut-off valve.
- F Pilot regulator adjustment point, this is set correctly at the factory and does not normally require adjustment.

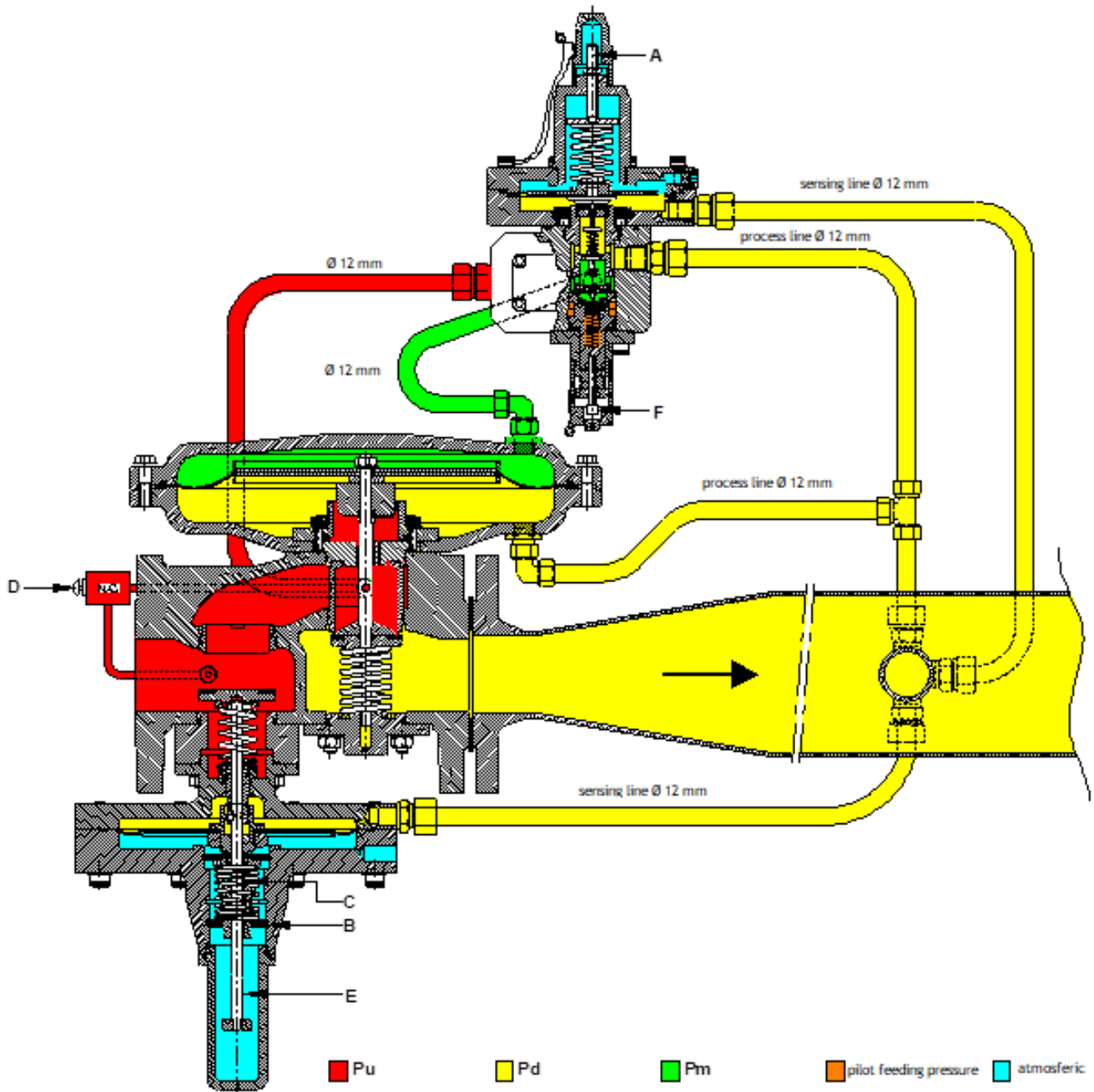

Figure 2

The response value of the minimum pressure protection, if any, is a fixed value (see label). If an existing minimum pressure relief valve is undesirable, it can be deactivated by removing the minimum spring (see C in figure 2). This can be accomplished by fully unscrewing the underlying bushing, removing the spring, and fully turning the bushing back in again.

3.3 Method of commissioning

Preset:

Turn "A" almost completely out (hexagonal wrench 4 mm) and make sure that the safety shut-off valve is closed.

- 1 Close the inlet and outlet valves.
- 2 Depressurize the outlet section after the regulator by opening the adjustment valve.
- 3 Close regulating valve.
- 4 Open inlet valve slowly.
- 5 Screw in "A" about 8 turns.
- 6 Check the safety shut-off valve for sealing function by reading the outlet pressure on the pressure gauge. In the case of continuously increasing pressure, the dysfunction must be repaired before point 7 starts.
- 7 Operate "D" until a stable pressure is created in the outlet section.
- 8 Pull "E" **carefully and upright** until it locks in place.
- 9 Check the function of the minimum pressure safety device (in absence, continue with point 10). Open the adjustment valve slightly to get a gasflow and slowly turn "A" to reduce the pressure. The safety shut-off valve should operate at an outlet pressure roughly equal to the minimum value indicated on the label. Turn "A" in 4 turns, actuate "D", then pull "E" gently and upright until it locks into place.
- 10 Check the operation of the maximum protection. Turn "A" slowly in. The safety shut-off valve should operate at an outlet pressure roughly equal to the maximum value stated on the final inspection report supplied. Turn "A" back four turns, and open the adjustment valve slightly to get a gasflow and close it when the outlet pressure approaches the adjustment value. Operate "D" and then gently pull "E" out until it locks in place.
Repeat this operation twice to check the reproducibility of the maximum pressure safety device. If the maximum protection value differs from the set point value, first follow points 10a and 10b and then go through point 10 again and continue.
 - 10a Open the regulating valve slightly and turn "A" to the desired maximum safety value of the safety shut-off valve, then close the regulating valve.
 - 10b Slowly unscrew "B" with the supplied key until the safety shut-off valve is activated.
- 11 Open the control valve slightly and set "A" to the desired setting. Slowly close the regulating valve and check the closing pressure.
- 12 Open the outlet valve and, if necessary, adjust the outlet pressure with "A" to the desired setting.
- 13 Secure "A" by hand tightening the nut with a wrench. Fit the protective covers of the pilot regulator and the safety shut-off valve.
- 14 If desired, the settings "A" and "F" can be sealed.

4. Adjusting the pilot

Adjusting the pilot can be carried out once the regulator has been put into operation (see chapter 3). The pilot of the RS350S has only **one** setting at which the operation is optimal. This setting is within about half a turn of the adjusting device “F” (see figure 2) relative to the zero point at which the pilot regulator is set at the factory.

If proper operation is not obtained during the adjustment in this area, this indicates a problem elsewhere in the gas pressure regulator/installation (see chapter 5).

Working method

Close the outlet valve, open the adjustment valve in such a way (e.g. approx. 1/8 turn) that the gas pressure regulator delivers a little. Adjust the outlet pressure approximately to the desired value P_d . Assess the pressure on the gauge: if the pressure varies periodically with a period time from 0.1 to 0.5 s (frequency 2 to 10 Hz) then the position of the adjustment valve must be changed slightly until the cycle time is greater than 0.5 s. In the case of a regulator which continues to oscillate structurally, it may be necessary to slightly dampen the gas pressure regulator by **temporarily** inserting a 5 mm hexagon wrench into the breather opening of the regulator.

Turn adjusting device “F” a quarter turn (the locknut should remain tight). The outlet pressure is regulated according to curve 1 in figure 3. Turn adjusting device “F” out very slowly (maximum half a turn): the amplitude and frequency decrease according to curve 2. Continue until the control becomes stable according to curve 3.



The last "adjustment twist" must always be in the **adjustment** direction.
After adjustment, install the sealing cap.

Adjust the outlet pressure to the desired value (e.g. using a digital manometer):

- $P_d > 50$ mbar: Set to desired value + 2.5% (AC2.5),
- $P_d < 50$ mbar: Set to desired value + 5% (AC5),

At 50% load, the regulator will regulate the outlet pressure with a value corresponding to the desired value.

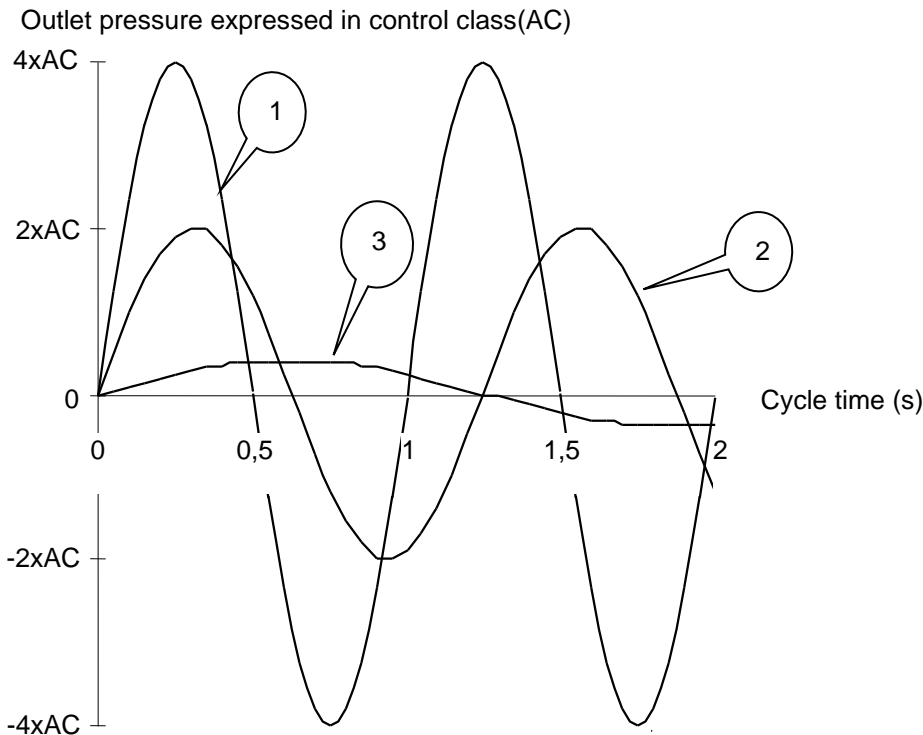

Figure 3

Figure 3 above illustrates the process of setting up RS350S graphically. The times indicated depend on the regulator model, inlet pressure and outlet pressure.

The spread of the times displayed are:

| | |
|-------------|----------------------------------|
| Situation 1 | Cycle time between 0.5 and 1 s |
| Situation 2 | transition from situation 1 to 3 |
| Situation 3 | Cycle time greater than 10 s |

When turning to a stable operation, for regulators with $P_d < 100$ mbar, it is clearly visible that when stable operation is reached, the regulated outlet pressure decreases slightly.

If the setting is set to the point where the outlet pressure just does not decrease, the closing pressure is minimal and the closing speed is maximal.



Tightening the lock nut after the last adjustment turn may slightly change the setting.

5. Verification of functioning

Open the adjusting valve about 1/8 turn so that the regulator delivers a little. The pressure should now be regulated in a stable way or varies within the control class. A prerequisite may be that the breather opening must be dampened with a hexagonal wrench (see chapter 4).

If the outlet pressure is regulated according to curve 2 in figure 3, then the regulator is in good condition, and will comply with the control class. Next, the pilot regulator must be adjusted as described in chapter 4.

If the outlet pressure shows a saw-tooth-shaped gradient with an amplitude (top-top value) greater than 4 times the control class (see figure 4), the condition is not optimal and the regulator should be maintained (see chapter 7).

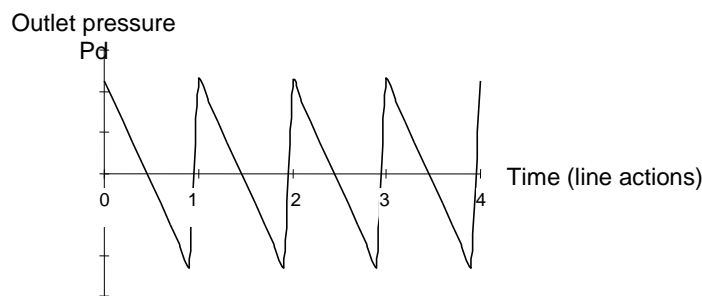

Figure 4

Usually the cause is false flow of the pilot pressure due to a leak in the connecting pipe P_m , but sometimes the cause is increased friction of the bearing in the regulator or pilot regulator. A station configuration that is different from what is prescribed, as shown in figure 1, as well as an obstacle in the vicinity of the output side of the drive can also lead to unstable behavior.

For example, it is possible that the regulator may start to exhibit unstable behavior when the delivery is changed by operating the control valve. By **temporarily** covering the breather opening of the regulator, the regulator can be stabilized again. The unstable behavior disappears when the control line valve is opened and the regulator supplies to the gas network.

Checking the closing pressure

Open the adjustment valve and measure the outlet pressure. Close the adjusting valve slowly, the pressure will increase slowly. Open the adjustment valve briefly so that the outlet pressure drops to a value that is approximately 3% higher than the just measured exhaust pressure. Now, the static closing pressure is created without the influence of control actions of the regulator.

| |
|-------------------------|
| $P_d > 50$ mbar, SG 5% |
| $P_d < 50$ mbar, SG 10% |

6. Decommissioning the gas pressure regulator



Work may only be carried out by an authorised employee, at a pressureless gas pressure regulator.

During the work, the gas present in the gas pressure regulator may be released, gas detection is necessary.

To take the gas pressure regulator out of operation, follow these steps:

- Close the inlet valve.
- Close the outlet valve.
- Depressurize the gas pressure regulator by slowly opening the regulating valve.



First depressurize the outlet section and only then depressurize the inlet section. This is to prevent the diaphragm dish from warping.

7. Maintenance

It is recommended to maintain the regulator preventively at an interval of 10 years. By applying an inspection system (e.g. PLEXOR® Inspection System) it is possible to deviate from this and maintenance can take place when the inspection system gives reason to do so. Maintenance should be performed according to service documentation *DDD3002MHEN*. Overhaul parts may be kept in stock for a maximum of 5 years (see date on packaging).

After maintenance, the controller should be checked for function. The following steps have to be completed:

- Check all disconnected connections for correctness.
- Check that all bolts and nuts are correctly tightened.
- Once the inlet and outlet pressures are in accordance with the regulator specifications, open the inlet valve.
- Check all partial seams for leaks.
- Adjust the pilot regulator to the desired outlet pressure (see Chapter 3).
- If necessary, adjust the regulator so that it delivers a stable flow (see chapter 4).
- Check the closing pressure,
- Check the function of the SSV, and if necessary adjust it to the desired shut-off value,
- Open the outlet valve and check the regulator operation.

8. Control procedures

Control procedures that can be carried out without taking the regulator out of service:

- Check for external gas tightness of regulator, pilot regulator and safety shut-off valve.
- Compare the regulated value with the set value.
- External visual inspection of the breather openings.

Control procedures that can be carried out when the regulator is taken out of operation (outlet valve in closed position, regulator under pressure):

- Regulated value; open the regulating valve so that the regulator supplies little gas, the regulated value is the value read from the pressure gauge that measures the outlet pressure,
- Closing pressure: close the adjustment valve slowly. Record the closing pressure after 3 minutes by means of the outlet pressure gauge,
- Internal gas tightness of the safety: let the safety call so that it closes. Depressurize the outlet part of the station by means of the adjustment valve and close it again. Record the pressure rise using the pressure gauge that measures the outlet pressure. If the pressure does not rise, the safety is closed,
- Internal gas tightness regulator and control pressure regulator.

If the controller is internally leaking, the position of the leak can be determined as follows:

- Leave the safety on so it closes,
- Depressurize the outlet part of the station by means of the adjustment valve and close it again.
- Remove the connection pipe Pu pilot regulator to Pe pilot regulator body and close the vacant connection at the regulator and the pilot regulator. Open the safety and record the pressure rise using the pressure gauge that measures exhaust pressure. If the pressure rises, the regulator or the control pressure regulator is leaking.

Pilot feeding pressure:





- Remove connection pipe Pm and connect a pressure gauge to the measuring connection Pup of the pilot regulator.
- Pressurize the regulator. Check the pilot feeding pressure when “A” (see figure 2) is screwed in (Pilot delivers pilot pressure), and when “A” is fully screwed out (closing pressure pilot). The measured values shall correspond respectively to 300 mbar ± 50 mbar.

See chapter 3 for switching values and reproducibility of the safety shut-off valve.

9. Regulator labels

Representation is informative.

Regulator general

| | | | |
|-------------------------------|----------------------|---|--|
| GAS PRESSURE REGULATOR | |  | Wigersma & Sikkema NL-6983 BP 4 Doesburg |
| Type | R350 | | |
| Reg. No | |  | 0085 0344 |
| Year | | | |
| T. Range | Class 2 (-20/+60 °C) |  | II 2G IIC T4 Gb |
| Medium | CNG (CH4) | | |
| Failure mode | Fail close |  | |
| Flange rating | PN16 | | |
| Standard | EN 334 | | |
| Type | IS | | |
| PS | 16 bar | | |
| P _{umax} | bar | | |
| DN | 50 mm | | |

Type model regulator
 T.Range temperature range, within which the controller can be used
 PS allowable pressure
 P_{umax} maximum inlet pressure at which it is still operating within its specifications
 DN nominal diameter

Insert indication on regulator

| |
|----------------------|
| R350 INSERT |
| Serial nr. |
| K_G |
| Valve Ø mm |

K_G throughput coefficient

Insert specific

| | | |
|--------------------|----------------------|---|
| R350 Insert | |  |
| Articlecode | K_G | |
| Serialnr. | Valve Ø mm | NL-6983 BP 4 |

K_G throughput coefficient

Pilot

| | | | |
|-------------------|-------------------------|---|-----------|
| PILOT | | Wigersma NL-6983 BP 4 Sikkema Doesburg | |
| Type | 350S | | |
| Serial. No | | | |
| Year | | | |
| T. Range | Class 2 (-20/+60 °C) | | |
| PS | 10 bar | AC | % |
| P _{umax} | bar | SG | % |
| P _{up} | 300 mbar (rel. to Pd) | W _{ds} | 0-50 mbar |
| P _m | 0-150 mbar (rel. to Pd) | W _d | 0-60 mbar |

- Type model pilot regulator
- T.Range temperature range within which the pilot regulator is to operate
- PS allowable pressure
- P_{umax} maximum inlet pressure at which it is still operating within specifications.
- P_{up} pilot feeding pressure, relative to outlet pressure Pd
- P_m motorization pressure
- AC accuracy class
- SG closing pressure class
- W_{ds} outlet pressure setting range with current setting spring
- W_d outlet pressure setting range with change of the setting spring

Safety shut-off valve

The SSD logistics label refers to a pressure range. The table below shows the meaning.

| Type | EN |
|------|--|
| LD | Low pressure |
| MD | Medium pressure |
| HD | Intermediate Pressure (2-7 bar) and high pressure (7-70 bar) |

| | | | |
|--|----------------------|---|--------|
| SAFETY SHUT-OFF DEVICE | | Wigersma NL-6983 BP 4 Sikkema Doesburg | |
| Type | S100 LD | PS | 10 bar |
| Reg. No | | P _{umax} | bar |
| Year | | A _{Go} | % |
| T. Range | Class 2 (-20/+60 °C) | A _{Gu} | % |
| Medium | CNG (CH4) | W _{Do} | mbar |
| Functional Class | | W _{Du} | mbar |
| SSD type | IS | W _{dso} | mbar |
| Valve seat Ø | 43.5 mm | W _{dsu} | mbar |
| Standard (EU) | EN 14382 | | |
| Medenus, Im Langen Feld 3, Olpe, Germany | | | |

| | |
|-----------|--|
| Serialnr. | |
| Type | |
| DN | |

- Type model safety shut-off valve
- T.Range temperature range within which the safety shut-off valve is to operate
- PS allowable pressure
- P_{umax} maximum inlet pressure at which the still functioning within the specifications.
- A_{Gu} accuracy class low pressure
- W_{Do} setting range overpressure with change of setting spring
- W_{Du} low pressure setting with setting spring
- A_{Go} accuracy class overpressure
- W_{dso} setting range overpressure at current setting spring
- W_{dsu} low pressure setting with current setting spring

10. Malfunction analysis



Temperature variations result in pressure differences (approx. 3 mbar/°C) in a closed volume. This must be taken into account when determining the closing pressure (especially at low pressures).

In general it can be said that a large internal leakage usually has its cause in the regulator, and small leakages usually have its cause in the control pressure regulator.

| Malfunction | Analysis |
|---|--|
| The regulator oscillates (vibrates) quickly when decreasing at an average low volume. | <ol style="list-style-type: none"> 1. Make sure that no restricted parts have been exchanged (restrictions provide damping). In the case of a high-volume decrease, the absence of restrictions will have less impact. 2. The adjustment of the pilot regulator has been disturbed. Re-regulate in accordance with paragraph 6.2 of chapter 6. 3. The regulator's membrane is or has been twisted. 4. Resistance on the drive's valve shaft. 5. Wave reflections from the exhaust section to the regulator, eliminating distortions (e.g. water in the pipe). <p>Note: A saw-tooth pendulum movement is the result of internal resistance to the bearing. Non-observance of the assembly instructions (see chapter 4) can adversely affect the operation.</p> |
| Regulator does not close completely, closing pressure too high | <p>Control order:</p> <ol style="list-style-type: none"> 1. Remove and plug the pilot line Pm from the inverter (for Pm, see label on the inverter). If the pressure remains too high, the cause is not in the pilot regulator, but in the regulator or the safety valve. 2. Close the safety valve. If the pressure in the exhaust section continues to increase, the cause can be found in the safety valve valve*. If the pressure no longer increases, the regulator is responsible for the malfunction (see 3 faults below). <p>*Theoretically, it is possible that both the pressure equalization pipe and the valve in the regulator are leaking at the same time. This can be checked by insulating the safety valve by disconnecting the control line.</p> |
| Pressure in the outlet continues to rise due to dysfunction of the pilot regulator | <p>If there is any damage or dirt in the inlet valve (see section 8.5.), this can cause leakage. This increases the pilot pressure.</p> |
| Pressure in the outlet continues to rise due to malfunctioning of the safety shut-off valve | <ol style="list-style-type: none"> 1. There is a connection between the inlet and the safety shut-off valve, allowing gas to flow through the control line to the outlet. O-ring leaks, allowing gas to flow along the shaft to the control line. 2. The valve does not fit the seat properly, allowing gas to flow past it. (Damage to seat and/or flap rubber). |
| Pressure in the outlet continues to rise due to dysfunction of the regulator | <ol style="list-style-type: none"> 1. The valve does not fit the seat properly, allowing gas to flow past it. (Damage to seat and/or flap rubber). 2. The pressure equalisation line causes a leak (the valve does not close). 3. There is a crack in the roller diaphragm, which allows gas to flow through the process line to the outlet at the inlet pressure. |

| Malfunction | Analysis |
|---|---|
| Exhaust pressure varies (widely). | <ol style="list-style-type: none"> 1 Setting of the pilot regulator is not correct. 2 The valve axis of the pilot regulator has resistance (friction). 3 Valve shaft of the regulator has resistance. 4 Breathing opening pilot regulator is clogged. 5 Influencing pipe/pilot pipe leaks. 6 Pilot regulator does not work properly (dirty). 7 False discharge of the pilot due to leakage of the Pm connection (see sticker on the housing for identification). 8 Inverter is used outside its specifications. |
| With a high flow, the outlet pressure decreases. | There is a tear in the main diaphragm of the regulator, which in case of increased demand, the greater pressure difference over the diaphragm cancels out the pilot, causing the regulator to close. In the event of a smaller demand, it is possible that the regulator will function properly, as less gas will escape above the diaphragm as a result of the smaller pressure differential. |
| Regulator remains closed independently of demand. | If the main diaphragm of the regulator ruptures (large opening), the pilot drops and the regulator is closed by the locking spring. |
| The regulator remains in the open position independently of the demand. | If the diaphragm of the pilot regulator ruptures, its valve is opened by the spring pressure of the pilot regulator. The regulator then receives an ever-increasing pressure above the main diaphragm of the regulator, which will increasingly open the valve. |
| Safety shut-off valve falls constantly, after a certain (same) time, after the inverter has been started. | <p>If the diaphragm of the auxiliary pressure regulator ruptures, the auxiliary pressure will be the same as the inlet pressure.</p> <p>The pilot regulator will control the regulator with an ever increasing pressure, which makes it more and more open. If the pressure in the exhaust area becomes too high, the Safety Shut-off Valve will come into operation.</p> <p>However, due to restrictions, the pressure build-up will be slow.</p> |
| Safety shut-off valve does not fall, whereas according to the prevailing exhaust pressure it should. | If the diaphragm of the safety shut-off valve ruptures, the pressure above and below the diaphragm will be the same, so that the safety shut-off valve will no longer be able to be addressed. |
| Safety shut-off valve cannot be reset with LD version | If the discharge pressure is less than 50 mbar, the measuring line of the safety shut-off valve must be equipped with a 3/2-valve N.O. so that the safety shut-off valve can be put back into operation without pressure. |
| Delivery regulator reacts slowly | No restriction in T-piece (pilot regulator). Line of influence leaking. |



When the pilot regulator has been disassembled, check whether it belongs to the regulator.

This can be seen on the delivery document, which contains the registration numbers of the regulator, safety valve and pilot regulator.

When disassembling the pilot regulator, it will have to be readjusted.

11. EU Declaration of Conformity



EU DECLARATION OF CONFORMITY No. 2019/353-04

This Declaration of Conformity is issued under the sole responsibility of the manufacturer

MANUFACTURER

| | |
|--------------|--|
| Company name | Wigersma en Sikkema B.V. |
| Full address | Leigraafseweg 4 6983 BP Doesburg The Netherlands |

EUROPEAN AUTHORISED REPRESENTATIVE

| | |
|--------------|--|
| Company name | Certification Company B.V. |
| Full address | Veluwezoom 42 1327 AH Almere The Netherlands |

IDENTIFICATION OF THE EQUIPMENT

| | |
|-------------------------------------|-------------------------------------|
| Generic denomination | Gas pressure regulator |
| Function | Controlling downstream gas pressure |
| Model | RS300S, RS350S PN10 – RS350S PN16 |
| PED conformity assessment procedure | Module B + D |

The object of the Declaration described above is in conformity with all relevant provisions of:

ATEX Directive 2014/34/EU; Pressure Equipment Directive (PED) 2014/68/EU

In conjunction with the following relevant harmonised standards or technical specifications

EN-ISO 80079-36:2016; EN 15198:2007; EN 334:2019; EN 14382:2019

The Notified Body DVGW CERT GmbH (0085) based at the Josef-Wirmer-Str. 1-3, 53123 in Bonn has conducted a EC type examination and issued the certificate no. CE-0085CS0392 (Module B) and for a EC quality assurance system the certificate no. SD-0085BQ0471 (Module D)

The Notified body DEKRA Certification B.V. (0344) based at Meander 1051, 6825 MJ in Arnhem has conducted the assessment as laid down in article 13, (1) (b) (ii) of the ATEX Directive 2014/34/EU and issued the confirmation letter with reference number 203104000-1912

Signed for and on behalf of the manufacturer and whom is also authorised is to manage the Technical File

| | | | |
|------------------------|---------------------------|-------------------|--|
| Place of issue: | Almere The Netherlands | Identity: | Mr. D. Rubio Borrajo |
| | | Function: | Regulatory Compliance Expert |
| Date of issue: | August 23, 2021 | Signature: |  |



Since 1921

Wigersma & Sikkema B.V.
Leigraafseweg 4
NL-6983 BP Doesburg
The Netherlands
TEL: +31 (0) 313 - 47 19 98
info@wigersma-sikkema.com
www.wigersma-sikkema.com



DDD3103GHEN/01-2025/rev. A1